

Tony Allison  
Design Engineer  
Halers Lighting Ltd.  
(part of Collingwood Lighting Ltd.)  
Brooklands House  
Sywell Aerodrome  
Sywell  
Northants NN6 0BT  
United Kingdom

**bre**

28<sup>th</sup> November 2011

Our Ref. 276028

Dear Mr Allison

**Robust Details Part E; Appendix F Acoustic Assessment of: Halers Lighting Ltd Downlights Halers H2 (untested) to Collingwood Lighting Limited FR01011 (CW133) Downlights (tested at BRE).**

Introduction: the Halers H2 downlight is manufactured by Halers Lighting Ltd. (which is a sister company of Collingwood Lighting Ltd). The Halers H2 is a second generation downlight of the FR01011 (CW133) downlight. This letter is an acoustic performance assessment (to Robust Details Part E; Appendix F) of how the Halers H2 downlight would compare with the FR01011 (CW133) downlight if installed in a Robust Details Appendix F floor.

Our assessment is based on:

- the test data contained in BRE test report number 251861 Laboratory airborne and impact sound insulation of Collingwood FR01011 (CW133) (fireLED) downlights in a Robust Details Appendix F floor;
- the information in Appendix F of Robust Details Part E, Resistance to the passage of sound;
- BRE's experience of testing downlights in accordance with the method described in Appendix F of Robust Details Part E, Resistance to the passage of sound.

The information provided on the FR01011 (CW133) downlight tested at BRE (BRE test report number 251861) is given in Table 1. The single number quantities for sound insulation included in BRE test report number 251861 were derived from measurements conducted in the BRE vertical transmission suite on 3<sup>rd</sup> March 2009 by Mr I West and Ms S King of BRE

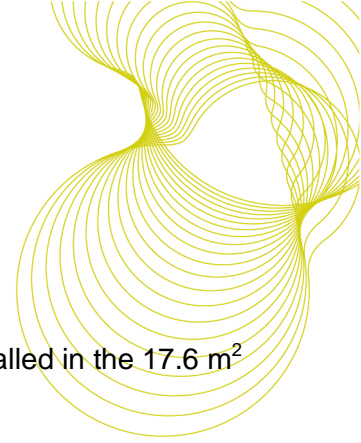

Acoustics. This data is reproduced in Table 2. Nine downlights were installed in the 17.6 m<sup>2</sup> ceiling of the Robust Details Appendix F floor for the tests.

**Table 1: data supplied for products tested at BRE**

Product reference	Type of downlight	Weight (g)	Required hole diameter (mm)	Can height (mm)
FR01011 (CW133)	Aluminium; fixed	320	60	84

**Table 2: results from BRE test report number 251861 and comparison with the Robust Details criteria**

Downlights installed	BRE UKAS Test number	$R_w + C_{tr}$ (dB)	$L_{n,w}$ (dB)	Test 2 - Test 1 (dB)	Test 3 - Test 4 (dB)
None	L209-025	31		NA	
	L209-026		79		NA
FR01011 (CW133)	L209-027	31		0	
	L209-028		79		0

Examination of Table 1 and Table 2 shows that:

- the difference with and without the downlights tested did not alter the single number quantities ( $R_w + C_{tr}$ ) for airborne or impact ( $L_{n,w}$ ) sound insulation of the Robust Details Appendix F floor when installed in its ceiling;

Table 3 contains the Halers H2 downlights assessed in this letter along with the weights of the downlights, the cut out hole diameters and the downlight can heights.

**Table 3: data supplied for products for which an opinion is required**

Product reference	Weight (g)	Required hole diameter (mm)	Can height (mm)
Halers H2	290	60	84

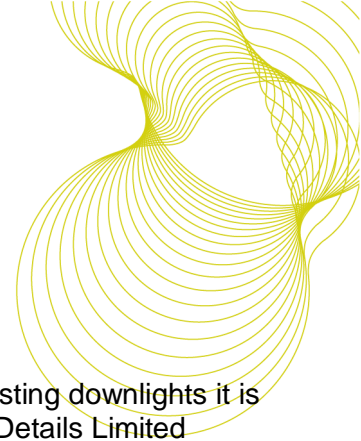

### **Assessment of Halers H2 downlights**

From the data in the BRE test report 251861 and BRE's experience of testing downlights it is our opinion that if the Halers H2 downlights were installed in the Robust Details Limited Appendix F floor they would perform as well as to the FR01011(CW133) downlights.

**Therefore, the Halers H2 downlights would pass the Appendix F of Robust details Part E test (Resistance to the passage of sound).**

Notes: The test method for the determination of the influence of the acoustic performance of Robust Details timber separating floors due to the presence of downlights (recessed lighting) is specified in Appendix F of Robust details Part E, Resistance to the passage of sound. The testing required is specified in F.3 of Appendix F and the performance required is specified in F.4 of Appendix F.

Yours sincerely, for and on behalf of BRE

Ian West  
Acoustics Laboratory Manager  
Building Technology Group  
BRE  
Telephone: +44 (0)1923 664208  
E-mail: [westi@bre.co.uk](mailto:westi@bre.co.uk)

Dr Paul Blackmore  
Associate Director  
Building Technology Group  
BRE

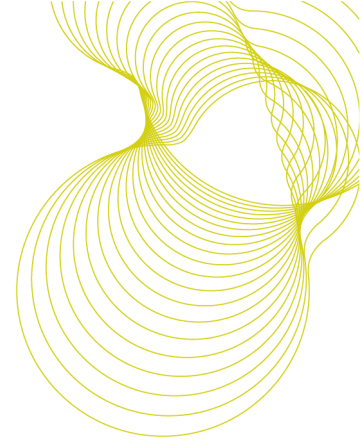

## Appendix

The product information provided for this assessment is shown in Table 4.

**Table 4: product information provided to BRE (tested at BRE)**

### FR01011 (CW133)

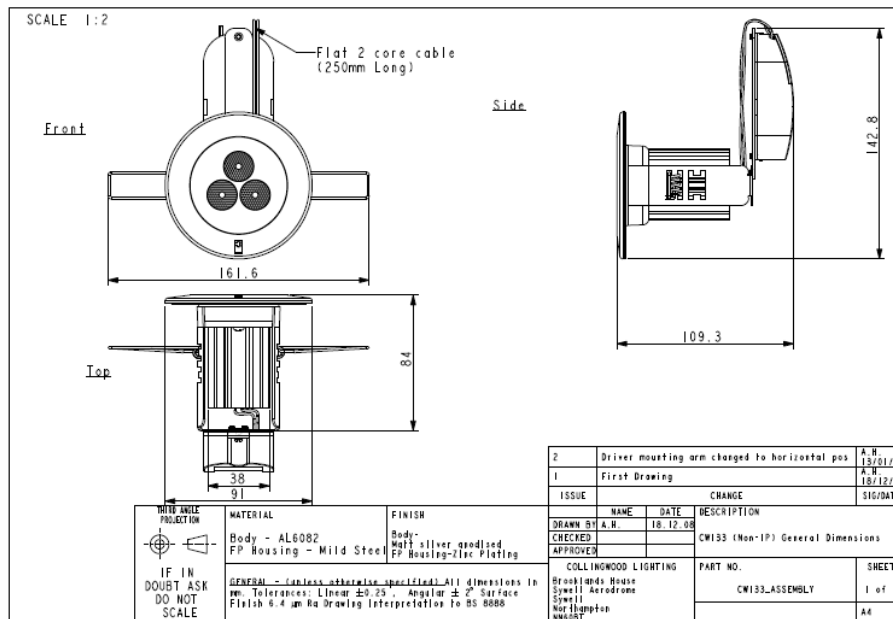

### Halers H2 (not tested at BRE)

